

UPC·MARATHON

OXYFIRE™ Oxygen Sensor Installation / Operation Manual



CONNECT WITH US



MASTERING
STRENGTH.
WORLDWIDE.



MANUAL #: 301

Revision #	Revision Date	Revision Description
003	13/11/2017	

THIS MANUAL IS SUPPLIED ELECTRONICALLY.

COPYRIGHT^(C)

No part of this publication may be reproduced, transmitted, transcribed, stored in a retrieval system, or translated into any language or computer language, in any form or by any means, electronic, mechanical, magnetic, optical, chemical, manual, or otherwise, without prior written permission of United Process Controls Inc. (UPC-Marathon).

The information contained in this document is STRICTLY CONFIDENTIAL and PROPRIETARY to UPC-Marathon, and shall not be: i) reproduced or disclosed in part or in whole, ii) used for any design or manufacturing of heat treating and/or control equipment, or any other purpose except for that which it is supplied under the terms of the Contract, unless the express written authorization is obtained from UPC-Marathon.

Drawings and photographs included in the documentation are the property of UPC-Marathon, and it is strictly forbidden to reproduce them, transmit them to a third party, or use them for manufacturing and/or design of equipment. Sub-licensing of any technical information contained in this Documentation is strictly forbidden under the terms of the Contract.

UPC-Marathon reserves the right to modify this document without prior notice.

DISCLAIMER:

The **Oxyfire™ Sensor** is to be used by the industrial operator under his/her direction. UPC-Marathon is not responsible or liable for any product, process, damage or injury incurred while using the **Oxyfire™ Sensor**. UPC-Marathon makes no representations or warranties with respect to the contents hereof and specifically disclaims any implied warranties or merchantability or fitness for any purpose.

TECHNICAL ASSISTANCE

For all questions or concerns regarding the operation of the **Oxyfire™ Sensor**, please consult the last page of this manual for contact information.



Table of Contents

1	INTRODUCTION.....	5
1.1	General.....	5
1.2	Overview	5
1.3	Theory of Operation.....	5
1.4	System Configuration	6
1.5	Standard Specifications.....	6
2	OXYFIRE™ MECHANICAL INFORMATION.....	7
3	INSTALLATION.....	9
3.1	Application Confirmation.....	9
3.2	Item Required.....	9
3.3	Xxxx.....	9
3.4	Installation Ports	9
3.5	Wall or Crown Thickness.....	10
3.6	Cool Installation (300°F or lower)	11
3.7	Hot Installation.....	11
4	OXYFIRE™ ELECTRICAL CONNECTION	12
4.1	Connection Cable	12
4.2	Output Signals.....	12
4.3	Terminal Head.....	12
4.4	Sensor Cable Insulation Color.....	12
5	REFERENCE AIR.....	13
5.1	Clean Dry Air Supply	13
6	VERIFICATION.....	14
6.1	Method #1	14
6.2	Method #2	14
7	TROUBLESHOOTING.....	15
7.1	Items Required	15
7.2	Steps for Troubleshooting	15
8	APPENDIX.....	16
8.1	Oxygen Calculation	16



8.2 Oxyfire™ Wiring Information 17

8.3 Oxygen/Temperature/Millivolt Chart 18

8.4 Thermocouple Type “B” Temperature/Millivolt Chart 19

8.5 Useful Formulas 20

9 CUSTOMER SUPPORT 21

Table of Figures

Figure 1: system configuration..... 6

Figure 2: Mechanical Info 8

Figure 3: installation ports..... 10

Figure 4: wall or crown thickness..... 11

Figure 5: head terminal wiring 13

Figure 6: head terminal wiring 14

Figure 7: wiring information 17

Figure 8: wire coloring 18

Figure 9: thermocouple temp/millivolt chart 20



1 INTRODUCTION

1.1 General

The OxyFire™ In-Situ Zirconia Oxygen Sensor has been designed to measure excess oxygen in a wide variety of combustion processes. It is an outstanding unit for monitoring oxygen concentrations in combustion gas of large or small boilers, industrial furnaces and combustion processes or for the control of low percent oxygen combustion.

The analyzer consists of a detector and converter. Optional accessories, such as electronics, reference air units, verification units, mounting assemblies, and protection tubes may be selected to enhance installation, add system care, minimize maintenance and automate verification. An optimal control system can be realized if the appropriate supplemental equipment is selected.

The OxyFire™ electronics utilize a high-performance microprocessor-based unit incorporating the latest technology. When combined with the proven, reliable output of the zirconia oxide sensor, the user receives an accurate, dependable oxygen concentration measurement needed for control and monitoring capabilities.

1.2 Overview

The OxyFire™ In-Situ Type Zirconia Oxygen Sensor is used to monitor and control the excess oxygen concentration in combustion gases of boilers, incinerators and other industrial furnaces.

A high-temperature sensor sampling gases from 1050°F (550°C) up to 3000°F (1600°C) is inserted into the process gas stream via a flange, threaded adaptor, or sealable opening. The sensor may be installed vertically or horizontally, depending on application specifics such as temperature, gas flow, etc. The atmosphere around the sensor tip should be moving and not stagnant. For optimum results, the sensor should be protected from direct flame contact and located at a point where combustion is complete.

NOTE: Sensors with alloy outer sheaths or alloy protection tubes should NOT be mounted horizontally WITHOUT consulting UPC-Marathon if temperatures exceed 1800°F (1000°C).

1.3 Theory of Operation

The high temperature sensor principle of measurement is zirconia based. During combustion operations an important natural phenomenon occurs. The yttria stabilized zirconia will conduct oxygen ions at temperatures above 1000°F (538°C). The driving force of the ion migration is the difference in the oxygen concentration of the process gas and the supplied reference air. Partial pressure laws of gases state that oxygen molecules will travel from higher to lower concentrations. A platinum electrode, located on both the inside and the outside of the zirconia, detects the voltage produced by the movement of the ions. This millivolt signal is a function of the difference in oxygen concentration. Knowing the process temperature,



reference gas oxygen concentration (20.9%) and the millivolt signal, the Nernst equation is used to calculate the percent oxygen.

The Nernst Equation is as follows:

$$E := \left(0.0215 \cdot \frac{\text{mV}}{\text{K}} \right) \cdot T \cdot \ln \left(\frac{\%O_{2_reference}}{\%O_{2_process}} \right)$$

E = Sensor Output in Millivolts

T = Sensor Temperature in degrees Kelvin (degrees C + 273)

%O_{2_Reference} = Oxygen concentration on the inside of the zirconia substrate (20.9%)

%O_{2_Process} = Oxygen concentration on the outside of the zirconia substrate (unknown)

ln() = Natural log

1.4 System Configuration

The basic system consists of a sensor, electronics and reference air unit.

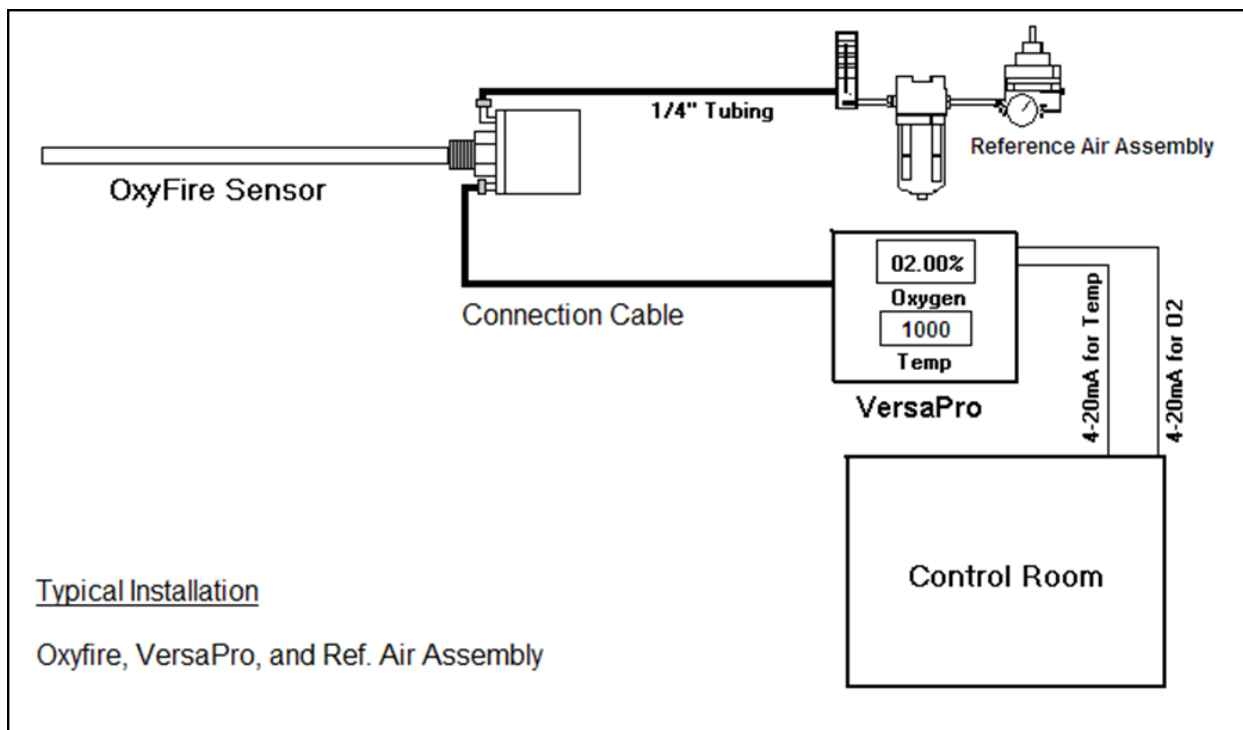

Figure 1: system configuration

1.5 Standard Specifications



Measurement Method	Zirconium Oxide
Net O ₂ Range	100ppm to 20.9%
Accuracy	+ 1.5% of observed process variable or 0.5% O ₂ , whichever is greater
Response Time	Less than 1 second for 98% of final value
Stability	Less than 1% deviation in signal output over the life of the sensor
Operating Temp Range	1000°F to 3000°F (550°C to 1600°C)
Temp Limit Terminal Head	300°F (149°C) max.
Mounting	Vertical or horizontal
Construction	
Inner Tube	Zirconia
Outer Sheath	Alumina, Silicon Carbide, HR-160 alloy, or (NONE)
Terminal Head	6061-T6 aluminum
Integral Thermocouple	Type "B" standard, "R" and "S" optional
Gas Calibration	Not required, verification of measurement available
Insertion Rate	1 inch (25mm) per 5 minutes during a hot installation
Sensor Output	Two millivolt output signals (Cell and thermocouple)
Connection Cable	Sensor to electronics
	B T/C: 8ft, 4-conductor twisted pair shielded Belden #89418 cable
	K, R, & S T/C: 8ft, 2 cables, 2-conductor, solid extension grade wires

2 OXYFIRE™ MECHANICAL INFORMATION

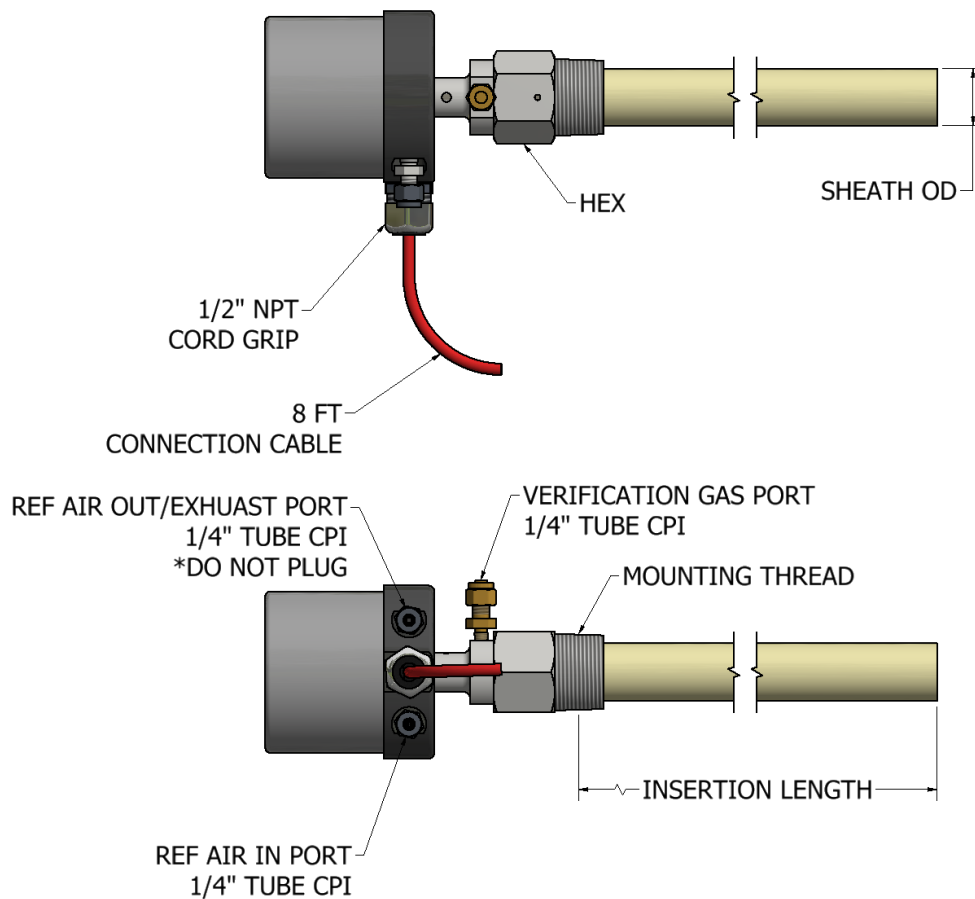

Figure 2: Mechanical Info

REF AIR OUT can be vented to a safe area, if process gas enters the head due to a breakage in the sensor. Maintain a minimum of back pressure on this port and ensure that the port is always open for reference air flow to circulate through the sensor.

OXYFIRE™ CONFIGURATIONS		
Insertion Depth	6", 12", 18"... 48"	6" Increments
Thermocouple Type	B, K, R, S, (None)	B type standard
SHEATH INFORMATION		
MATERIAL	SHEATH OD	MOUNTING THREAD
Alumina	1.25"	1.25" NPT (1.75" HEX)
Silicon Carbide	1.25"	1.25" NPT (1.75" HEX)
High Temp Alloy	1.05"	1.00" NPT (1.50" HEX)



3 INSTALLATION

3.1 Application Confirmation

Call your local UPC Representative or UPC directly when planning your sensor installation. The sensor location and depth of insertion are critical factors to consider and vary with different applications. UPC Application Engineers are equipped to help with such information for glass melting, reheat furnaces, incinerators, process heaters, boilers, kilns, and many other applications.

3.2 Item Required

To perform a sensor installation, you will need the following items:

Supplied with standard OxyFire™ models:

B T/C models: Teflon coated copper wire, four conductor, stranded, 18 gauge, twisted pair, shielded – Belden #89418

R & S T/C models: 2 cables, 2-conductor solid extension wires

Ceramic fiber blanket insulation and/or refractory cement.

Sensor Reference Air: Clean, dry continuous air source – approximately 2 psi at a flow of 50 to 150cc/minute

Cooling Air: If the temperature of the sensor terminal head will exceed 300°F (148°C), air should be blown across it to reduce the temp. The cooling air should be directed to flow perpendicular across the sensor head.

3.3 Xxxx

The installation hole, through the refractory of the crown or wall, should be a minimum of 2 inches (50mm) in diameter. The hole should always be straight, clean, and perpendicular to the wall or crown. Certain applications including those using the OxyFire™ “XR” style sensor, require a hole with a 3 inch (75mm) diameter or larger. Verify the required hole size with MMI engineers before drilling. **It is advised to always verify the hole size required for your application and sensor. UPC Application Engineers can help with this matter.**

3.4 Installation Ports

The ports can be of different designs – open hole, threaded, and flanged. Applications with exterior metal shells should use threaded or flanged type ports. Thread is 1.25” NPT size for the standard OxyFire™. Applications with ceramic exterior shells may use the open hole, threaded, or flanged connection ports. The flange or pipe will be cemented in to the refractory.

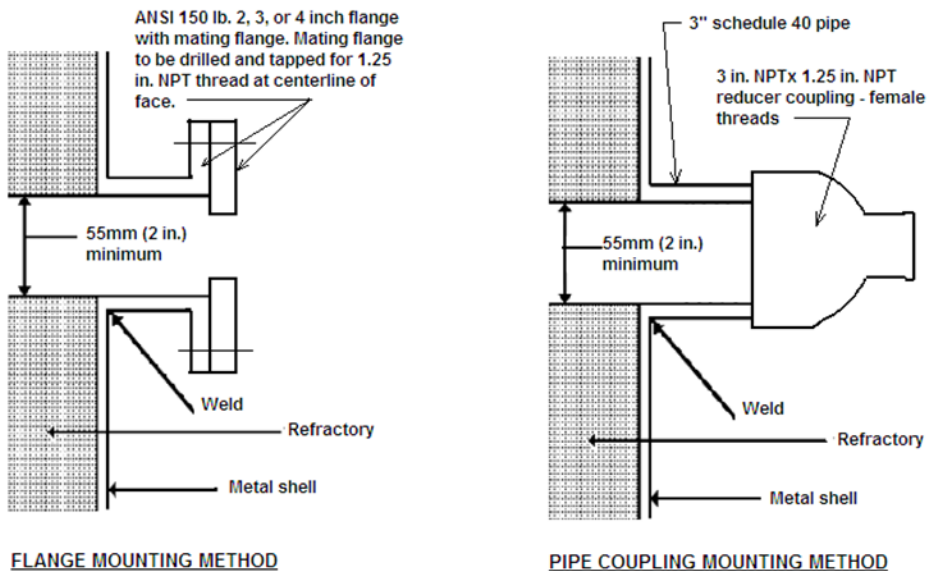

The methods above may be used on boilers and furnaces with refractory lined metal shells. Installations are good for temperatures up to 1600 deg. C.

Figure 3: installation ports

3.5 Wall or Crown Thickness

Verify the exact thickness of the refractory in the crown or wall. A length of high temperature metal wire, formed like an "L", should be inserted into the refractory hole. Hook the lengths of wire against the inside face of the refractory and mark the outside face of the furnace on the wire. Check the dimension at several points around the circumference of the hole. This will indicate possible erosion or build-up. Transfer this mark to the sensor sheath. Next mark 1 inch (25mm) increments along the length of the sensor sheath starting at the tip.

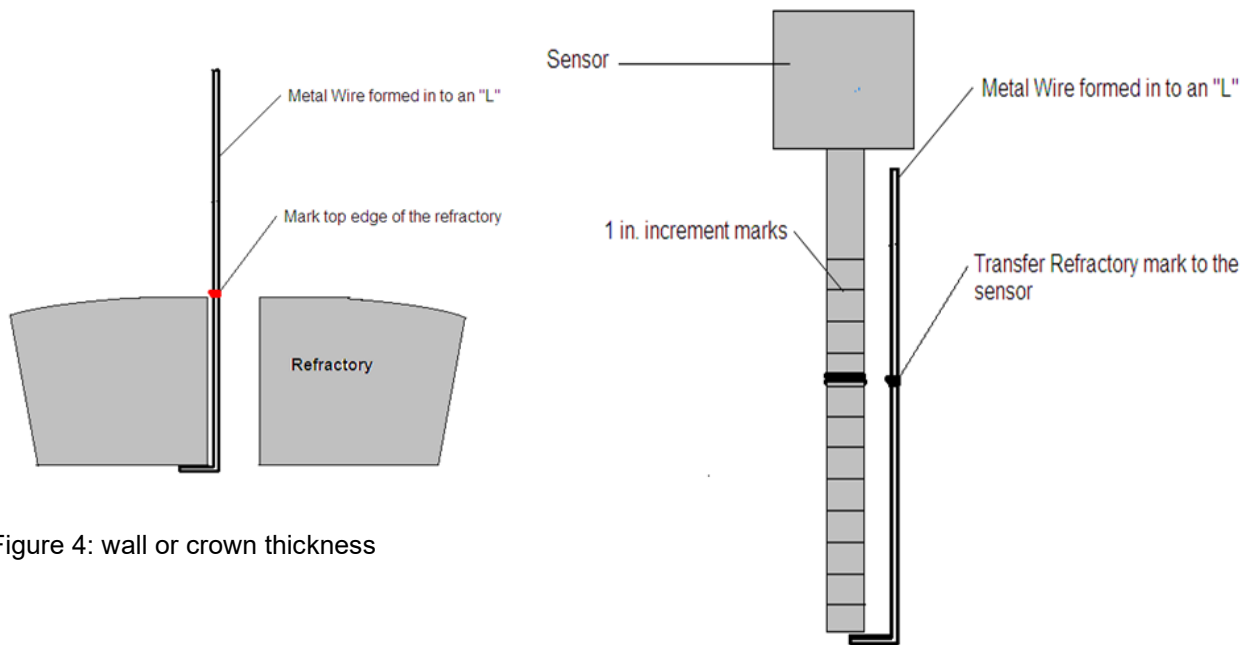

Figure 4: wall or crown thickness

3.6 Cool Installation (300°F or lower)

If the installation is cool, you may insert the entire sensor at once and seal or tighten the port connection to avoid any air in-leakage. Apply Teflon tape or thread sealant to the sensor threads before installing. Carefully hand-tighten the sensor. Then using a wrench, tighten one-quarter turn. Over tightening the sensor can cause breakage. Connect the reference air supply to correct fitting on sensor. Verify that the cap on the verification fitting is tight.

3.7 Hot Installation

Before inserting the sensor, verify the presence of a flame exiting the port & apply Teflon tape or thread sealant to the sensor threads before installing.

. If a flame is not observed, follow these installation procedures:

You may insert the first 4 to 6 inches (100 to 150mm) of the sensor in to the port. This dimension should not exceed one half of the refractory thickness. Then begin the slow insertion rate of 1 inch (25mm) per 5 minutes to prevent thermal shock to the sensor. Keep the sensor supported during the insertion process. Carefully hand-tighten the sensor once completely installed. Then using a wrench, tighten one-quarter turn. Over tightening the sensor can cause damage to the sheath. If the threaded connection is not used, carefully seal the hole around the sensor with insulation and/or cement. Connect the reference air supply to correct fitting on sensor. Verify that the cap on the verification fitting is tight.

An insertion rate faster than specified can cause irreparable damage to the sensor



If a flame is observed exiting the installation port, contact UPC engineers before starting sensor insertion

4 OXYFIRE™ ELECTRICAL CONNECTION

4.1 Connection Cable

Each sensor is supplied with an 8 ft (2.4 meters) connection cable. The connection cable is used for wiring directly to the instrument before installation. If a longer connection cable length is required, please specify when ordering.

4.2 Output Signals

Both of the sensor output signals are millivolt, no current flow.

4.3 Terminal Head

Do not physically pull on any of the wires in the terminal head. The internal platinum wires are very delicate; any extra force could cause premature failure. Only remove the head for troubleshooting purposes.

4.4 Sensor Cable Insulation Color

B' connection cable is a single RED sheathed cable with 4-conductor
'K', 'R', & 'S' cables are two separate cables

ELECTRICAL CONNECTION	'B' TC INSULATION COLOR	'R' & 'S' TC INSULATION COLOR	'K' TC INSULATION COLOR
SENSOR (+)	RED	BLACK (GREY SHEATH)	BLACK (GREY SHEATH)
SENSOR (-)	WHITE	WHITE (GREY SHEATH)	WHITE (GREY SHEATH)
TC (+)	GREEN	BLACK (GREEN SHEATH)	YELLOW (YELLOW SHEATH)
TC (-)	BLACK	RED (GREEN SHEATH)	RED (YELLOW SHEATH)



HEAD TERMINAL WIRING DO NOT TAMPER WITH INTERNAL WIRING

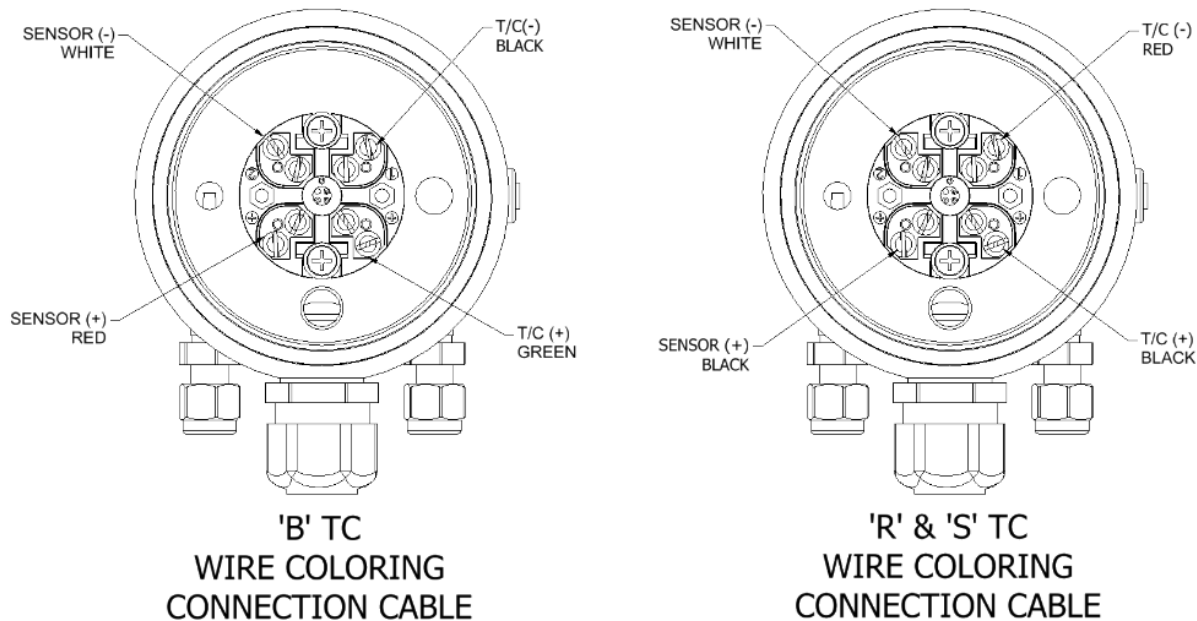

Figure 5: head terminal wiring

5 REFERENCE AIR

5.1 Clean Dry Air Supply

The sensor requires a supply of clean, dry air at a flow rate of 50 to 150cc/min. at a pressure of approximately 2 psi. Sources for the air supply are regulated, clean plant instrument air or atmospheric air from a small pump unit. UPC offers suitable reference air supply units.

Part #F005010 – Reference Air Assembly – Includes regulator, filter, flow meter, and interconnecting stainless steel tubing and fittings. For use with customer plant instrument air supply. May be used for multiple sensors.

Part #F005026 – Reference Air Panel – Includes pre-wired and plumbed enclosure with atmospheric pump and flow meter. For use when plant instrument air is not available. One reference air panel per sensor. Requires 120 VAC power supplied by customer.

Suitable ¼" tubing for the application, such as poly/teflon, copper, aluminum, or stainless steel should be run from the reference air supply to the sensor.

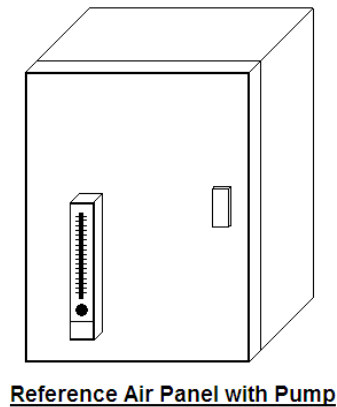
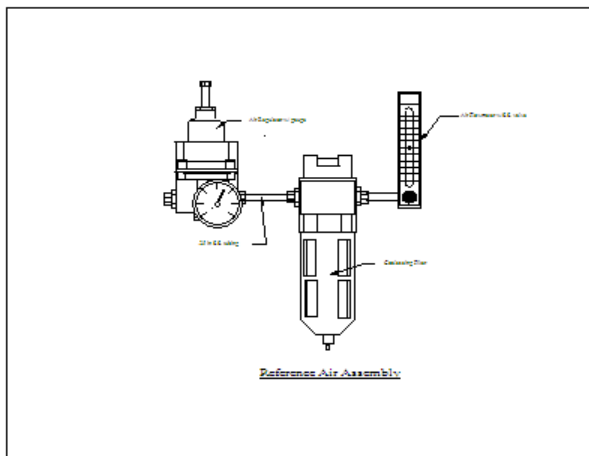

Figure 6: head terminal wiring

6 VERIFICATION

The oxygen sensor does not require calibration with a certified calibration gas. The standard OxyFire™ does include a port and fitting for verification of the oxygen measurement and operation of the cell. There are two common methods used in the verification process.

6.1 Method #1

Method #1 is to inject a certified calibration gas in to the verification port and compare the sensor reading to the cal gas. The calibration gas should be regulated to 5 psi maximum and a flow rate not to exceed 2 scfh. The calibration gas will need to exceed the process gas flow and pressure. The calibration gas will disperse the process gas contained inside the sensor's outer sheath and allow the cell to measure the calibration gas. If the cal gas flow does not disperse the process gas completely, there will be a slight blending of process and cal gases at the cell. This can cause the sensor's readings to vary slightly from the actual cal gas. It is recommended to start the cal gas flow at 2 psi and slowly increase to a maximum of 5 psi if required.

6.2 Method #2

Method #2 is to use a portable extractive oxygen analyzer to extract a gas sample from the sensor's verification port and compare the portable reading to the sensor reading. Care should be taken to make sure the portable analyzer is calibrated and accurate. After completing this process, remember to replace the cap on the verification fitting and tighten to prevent any in-leakage.



7 TROUBLESHOOTING

7.1 Items Required

The following items are required to troubleshoot the OxyFire™ sensor.

A digital multimeter (with DC millivolt ranges)

Blade and Phillips screwdrivers

Needle-nose pliers

Verification gas or portable oxygen analyzer

Oxygen/Temp/Millivolt Chart (See Appendix)

Thermocouple millivolt/temp chart for thermocouple supplied with a standard “B” sensor only (See Appendix).

Sensor wiring schematic (See Appendix)

7.2 Steps for Troubleshooting

Sensor must be in the process at normal operation; above 1050°F (550°C) temperature

Use a portable analyzer or verification gas to verify sensor reading

If sensor does not verify or the verification cannot be performed, proceed to **step c**.

Verify that the reference air tubing is connected to the correct port on the sensor. Verify that the verification port on the sensor is capped tightly to prevent any air in-leakage. Check sensor reference air for proper flow and pressure. Verify air is reaching sensor port by disconnecting the supply tubing at the sensor and place the tubing in a cup of water. If you see no bubbles or a very slow flow of bubbles, increase the reference air flow at the supply until a steady flow of bubbles is achieved. Dry and reconnect the air tubing to the sensor port and proceed to **step d**. A higher than normal oxygen reading may be observed if the reference air flow is low. A lower than normal reading may be observed if the pressure and flow is too high.

The sensor is supplied with a cable approximately 8 feet long. It is attached to the terminal screws inside the terminal head of the sensor. If the cable has not been removed then follow these steps:

Isolate the sensor from the rest of the system by disconnecting the sensor cable

Using the sensor cable, measure and note the cell millivolts across the (+) wire and the (-) wire. This measurement should fluctuate. Next, measure and note the thermocouple millivolts across the (+) wire and the (-) wire. This measurement should be fairly stable

Using the charts in the appendix, look up the temperature and oxygen. Compare the readings to what you were seeing in the electronics. They should match. If the readings do not match, reconnect the wires to the cable running to the electronics. Measure the same millivolt readings at the terminals on the electronics. They should match. If not, trace all wires and connections to see if they are crossed or connected in error. The shield wire should only be connected at the electronics. If everything checks out, then disconnect the shield to see if a



ground loop or interference is involved. If everything checks out OK and the readings are still incorrect, call Marathon Monitors Inc. for further assistance.

If the factory cable has been removed:

Remove the terminal cover from the sensor and verify that all connections are correct. See Appendix.

Isolate the sensor from the rest of the system by disconnecting the cable from the terminal connections inside the sensor terminal head. Make note of wiring connections before disconnecting. Do not disconnect the sensor's internal wires or damage to the sensor may occur.

Measure and note the cell millivolts across the internal (+) wire and the (-) wire. This measurement should fluctuate. Next, measure and note the thermocouple millivolts across the (+) wire and the (-) wire. This measurement should be fairly stable (see diagram on page 13 for wire color and location).

Using the charts in the appendix, look up the temperature and oxygen. Compare the readings to what you were seeing in the electronics. They should match. If the readings do not match, reconnect the cable running to the electronics. Measure the same millivolt readings at the terminals on the electronics. They should match. If not, trace all wires and connections to see if they are crossed or connected in error. The shield wire should only be connected at the electronics. If everything checks out, then disconnect the shield to see if a ground loop or interference is involved. If everything checks out OK and the readings are still incorrect, call United Process Controls Inc. for further assistance.

8 APPENDIX

8.1 Oxygen Calculation

A natural phenomenon occurs when zirconia oxide is heated above 550° C. and a reference gas is on one side and an unknown atmosphere containing the same component as the reference gas is on the other side. As long as these two atmospheres are kept separate, ions of the reference gas will transfer across the zirconia boundaries, going from area of greatest concentration to area of least concentration. Electrodes of various materials are used to measure the ion electrons (+/-) flowing through the zirconia oxide. This signal (millivolts) is generated as long as a reference gas is continuously supplied. In the area of combustion control, the reference gas is typically air (20% Oxygen and 80% Nitrogen). Knowing that there is Oxygen present in the combustion process, allows the in-situ oxygen sensor (it's substrate being made of zirconia oxide) to measure the oxygen ion transfer across the substrate, and thus give a millivolt signal that is inversely proportional to the amount of Oxygen present in the combustion zone. Walther Hermann Nernst, the German physical chemist is credited with developing the "Theory of Solutions". This theory explains the voltages developed by electrochemical batteries. This universally accepted equation can be applied to the sensing of Oxygen using a zirconia oxide cell. UPC's oxygen sensors and their electrical interfaces conform to the Nernst Equation in combustion environments. In most combustion applications,



the level of excess Oxygen range from 0.001ppm to 21% oxygen. The equation allows the computation and display of the oxygen concentration in the combustion gas stream. The sensors and electronics are virtually maintenance free, needing no calibration and no maintenance of sample tubing.

The Nernst Equation is as follows:

$$E := \left(0.0215 \cdot \frac{\text{mV}}{\text{K}} \right) \cdot T \cdot \ln \left(\frac{\%O_2_{\text{reference}}}{\%O_2_{\text{process}}} \right)$$

E = Sensor Output in Millivolts

T = Sensor Temperature in degrees Kelvin (degrees C + 273)

%O₂_Reference = Oxygen concentration on the inside of the zirconia substrate (20.9%)

%O₂_Process = Oxygen concentration on the outside of the zirconia substrate (unknown)

ln() = Natural log

Sample Solution:

$$T = 1273\text{K} \quad E = 80\text{mv}$$

$$80 = (0.0215)(T)(\ln (20.9/\text{Ln } X))$$

$$80 = (0.0653)(T) - (0.0215)(T)(\ln X)$$

$$80 = 83.13 - (0.0215)(1273)(\ln X)$$

$$(27.37)(\ln X) = 83.13 - 80$$

$$\ln X = 3.13/27.37$$

$$\ln X = 0.114$$

$$X = 1.12\% \text{ oxygen}$$

8.2 Oxyfire™ Wiring Information

'B' TC INSULATION COLOR (RED SHEATH)	'R' & 'S' TC INSULATION COLOR	ELECTRICAL CONNECTION
RED	BLACK (GREY SHEATH)	SENSOR (+)
WHITE	WHITE (GREY SHEATH)	SENSOR (-)
GREEN	BLACK (GREEN SHEATH)	THERMOCOUPLE (+)
BLACK	RED (GREEN SHEATH)	THERMOCOUPLE (-)

Figure 7: wiring information



HEAD TERMINAL WIRING DO NOT TAMPER WITH INTERNAL WIRING

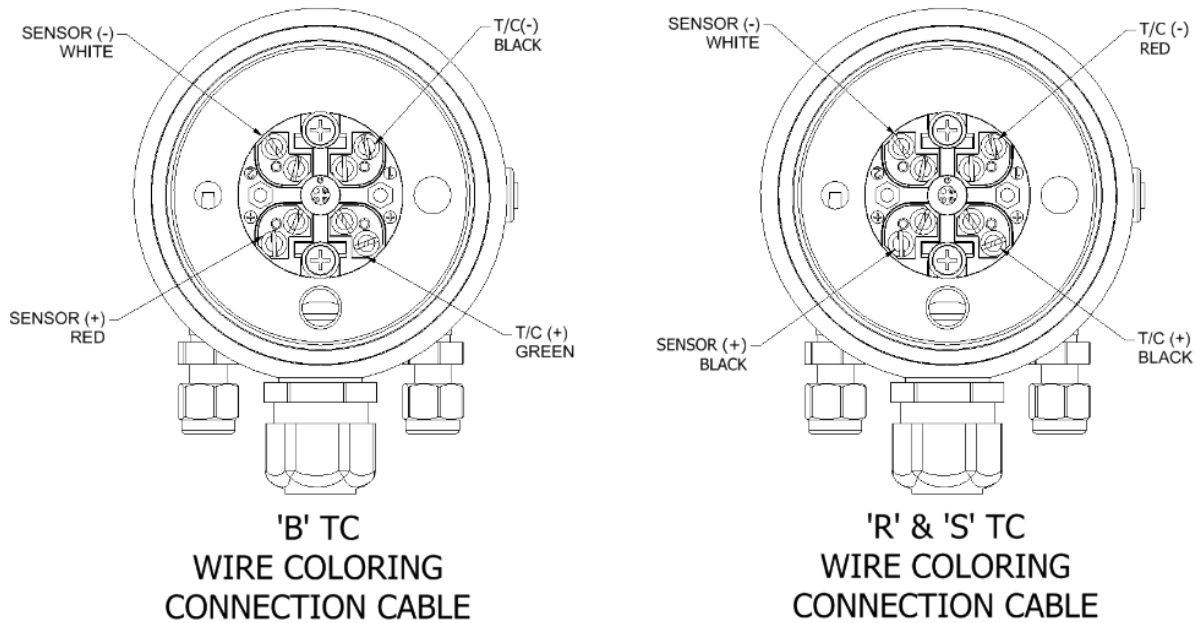

Figure 8: wire coloring

8.3 Oxygen/Temperature/Millivolt Chart



Temp		SENSOR OUTPUT IN MILLIVOLTS																					
C	F	10	20	30	40	50	60	70	80	90	100	110	120	130	140	150	160	170	180	190	200	210	220
600	1112	12.3	7.2	4.2	2.5	1.5	0.9	0.5	0.3	0.2	0.1	0.1	0.0	0.0	0.0	0.0	0.0	0.0	0.0	0.0	0.0	0.0	0.0
625	1157	12.5	7.4	4.4	2.6	1.6	0.9	0.6	0.3	0.2	0.1	0.1	0.0	0.0	0.0	0.0	0.0	0.0	0.0	0.0	0.0	0.0	0.0
650	1202	12.7	7.6	4.6	2.7	1.7	1.0	0.6	0.4	0.2	0.1	0.1	0.1	0.0	0.0	0.0	0.0	0.0	0.0	0.0	0.0	0.0	0.0
675	1247	12.8	7.8	4.8	2.9	1.8	1.1	0.7	0.4	0.3	0.2	0.1	0.1	0.0	0.0	0.0	0.0	0.0	0.0	0.0	0.0	0.0	0.0
700	1292	13.0	8.0	5.0	3.1	1.9	1.2	0.7	0.5	0.3	0.2	0.1	0.1	0.0	0.0	0.0	0.0	0.0	0.0	0.0	0.0	0.0	0.0
725	1337	13.1	8.2	5.2	3.2	2.0	1.3	0.8	0.5	0.3	0.2	0.1	0.1	0.1	0.0	0.0	0.0	0.0	0.0	0.0	0.0	0.0	0.0
750	1382	13.3	8.4	5.3	3.4	2.2	1.4	0.9	0.6	0.4	0.2	0.1	0.1	0.1	0.0	0.0	0.0	0.0	0.0	0.0	0.0	0.0	0.0
775	1427	13.4	8.6	5.5	3.5	2.3	1.5	0.9	0.6	0.4	0.3	0.2	0.1	0.1	0.0	0.0	0.0	0.0	0.0	0.0	0.0	0.0	0.0
800	1472	13.6	8.8	5.7	3.7	2.4	1.6	1.0	0.7	0.4	0.3	0.2	0.1	0.1	0.1	0.0	0.0	0.0	0.0	0.0	0.0	0.0	0.0
825	1517	13.7	9.0	5.9	3.8	2.5	1.7	1.1	0.7	0.5	0.3	0.2	0.1	0.1	0.1	0.0	0.0	0.0	0.0	0.0	0.0	0.0	0.0
850	1562	13.8	9.1	6.0	4.0	2.6	1.7	1.2	0.8	0.5	0.3	0.2	0.2	0.1	0.1	0.0	0.0	0.0	0.0	0.0	0.0	0.0	0.0
875	1607	14.0	9.3	6.2	4.1	2.8	1.8	1.2	0.8	0.6	0.4	0.2	0.2	0.1	0.1	0.1	0.0	0.0	0.0	0.0	0.0	0.0	0.0
900	1652	14.1	9.5	6.4	4.3	2.9	1.9	1.3	0.9	0.6	0.4	0.3	0.2	0.1	0.1	0.1	0.0	0.0	0.0	0.0	0.0	0.0	0.0
925	1697	14.2	9.6	6.5	4.4	3.0	2.0	1.4	0.9	0.6	0.4	0.3	0.2	0.1	0.1	0.1	0.0	0.0	0.0	0.0	0.0	0.0	0.0
950	1742	14.3	9.8	6.7	4.6	3.1	2.1	1.5	1.0	0.7	0.5	0.3	0.2	0.2	0.1	0.1	0.1	0.0	0.0	0.0	0.0	0.0	0.0
975	1787	14.4	9.9	6.8	4.7	3.2	2.2	1.5	1.1	0.7	0.5	0.4	0.2	0.2	0.1	0.1	0.1	0.0	0.0	0.0	0.0	0.0	0.0
1000	1832	14.5	10.1	7.0	4.9	3.4	2.3	1.6	1.1	0.8	0.5	0.4	0.3	0.2	0.1	0.1	0.1	0.0	0.0	0.0	0.0	0.0	0.0
1025	1877	14.6	10.2	7.1	5.0	3.5	2.4	1.7	1.2	0.8	0.6	0.4	0.3	0.2	0.1	0.1	0.1	0.1	0.0	0.0	0.0	0.0	0.0
1050	1922	14.7	10.4	7.3	5.1	3.6	2.5	1.8	1.3	0.9	0.6	0.4	0.3	0.2	0.2	0.1	0.1	0.1	0.0	0.0	0.0	0.0	0.0
1075	1967	14.8	10.5	7.4	5.3	3.7	2.6	1.9	1.3	0.9	0.7	0.5	0.3	0.2	0.2	0.1	0.1	0.1	0.0	0.0	0.0	0.0	0.0
1100	2012	14.9	10.6	7.6	5.4	3.8	2.7	2.0	1.4	1.0	0.7	0.5	0.4	0.3	0.2	0.1	0.1	0.1	0.1	0.0	0.0	0.0	0.0
1120	2048	15.0	10.7	7.7	5.5	4.0	2.8	2.0	1.5	1.1	0.8	0.5	0.4	0.3	0.2	0.1	0.1	0.1	0.1	0.0	0.0	0.0	0.0
1150	2102	15.1	10.9	7.8	5.7	4.1	2.9	2.1	1.5	1.1	0.8	0.6	0.4	0.3	0.2	0.2	0.1	0.1	0.1	0.0	0.0	0.0	0.0
1175	2147	15.2	11.0	8.0	5.8	4.2	3.0	2.2	1.6	1.2	0.8	0.6	0.4	0.3	0.2	0.2	0.1	0.1	0.1	0.1	0.0	0.0	0.0
1200	2192	15.3	11.1	8.1	5.9	4.3	3.1	2.3	1.7	1.2	1.0	0.7	0.5	0.3	0.3	0.2	0.1	0.1	0.1	0.1	0.0	0.0	0.0
1225	2201	15.4	11.2	8.2	6.0	4.4	3.2	2.4	1.7	1.3	0.9	0.7	0.5	0.4	0.3	0.2	0.2	0.1	0.1	0.1	0.0	0.0	0.0
1250	2282	15.4	11.4	8.4	6.2	4.5	3.3	2.5	1.8	1.3	1.0	0.7	0.5	0.4	0.3	0.2	0.2	0.1	0.1	0.1	0.1	0.0	0.0
1275	2327	15.5	11.5	8.5	6.3	4.7	3.5	2.6	1.9	1.4	1.0	0.8	0.6	0.4	0.3	0.2	0.2	0.1	0.1	0.1	0.1	0.0	0.0
1300	2372	15.6	11.6	8.6	6.4	4.8	3.6	2.6	2.0	1.5	1.1	0.8	0.6	0.5	0.3	0.3	0.2	0.1	0.1	0.1	0.1	0.0	0.0
1325	2417	15.7	11.7	8.7	6.5	4.9	3.7	2.7	2.0	1.5	1.1	0.9	0.6	0.5	0.4	0.3	0.2	0.2	0.1	0.1	0.1	0.1	0.0
1350	2462	15.7	11.8	8.9	6.6	5.0	3.7	2.8	2.1	1.6	1.2	0.9	0.7	0.5	0.4	0.3	0.2	0.2	0.1	0.1	0.1	0.1	0.0
1375	2507	15.8	11.9	9.0	6.8	5.1	3.8	2.9	2.2	1.7	1.2	0.9	0.7	0.5	0.4	0.3	0.2	0.2	0.1	0.1	0.1	0.1	0.0
1400	2552	15.9	12.0	9.1	6.9	5.2	3.9	3.0	2.3	1.7	1.3	1.0	0.7	0.6	0.4	0.3	0.2	0.2	0.1	0.1	0.1	0.1	0.1
1425	2597	15.9	12.1	9.2	7.0	5.3	4.0	3.1	2.3	1.8	1.4	1.0	0.8	0.6	0.5	0.3	0.3	0.2	0.2	0.1	0.1	0.1	0.1
1450	2642	16.0	12.2	9.3	7.1	5.4	4.1	3.2	2.4	1.8	1.4	1.1	0.8	0.6	0.5	0.4	0.3	0.2	0.2	0.1	0.1	0.1	0.1
1475	2687	16.1	12.3	9.4	7.2	5.5	4.2	3.3	2.5	1.9	1.5	1.1	0.9	0.7	0.5	0.4	0.3	0.2	0.2	0.1	0.1	0.1	0.1
1500	2732	16.1	12.4	9.5	7.3	5.6	4.3	3.3	2.6	2.0	1.5	1.2	0.9	0.7	0.5	0.4	0.3	0.2	0.2	0.1	0.1	0.1	0.1
1525	2777	16.2	12.5	9.6	7.4	5.7	4.4	3.4	2.6	2.0	1.6	1.2	0.9	0.7	0.6	0.4	0.3	0.3	0.2	0.2	0.1	0.1	0.1
1550	2822	16.2	12.6	9.7	7.5	5.8	4.5	3.5	2.7	2.1	1.6	1.3	1.0	0.8	0.6	0.5	0.4	0.3	0.2	0.2	0.1	0.1	0.1
1575	2867	16.3	12.6	9.8	7.6	5.9	4.6	3.6	2.8	2.2	1.7	1.3	1.0	0.8	0.6	0.5	0.4	0.3	0.2	0.2	0.1	0.1	0.1
1600	2912	16.3	12.7	9.9	7.7	6.0	4.7	3.7	2.9	2.2	1.7	1.4	1.1	0.8	0.7	0.5	0.4	0.3	0.2	0.2	0.2	0.1	0.1

Oxygen %

8.4 Thermocouple Type “B” Temperature/Millivolt Chart



TYPE "B" Temperature/Millivolt Chart

TEMP F	TEMP C	MILLIVOLTS
1000	538	1.44
1050	565	1.59
1100	593	1.75
1150	621	1.92
1200	649	2.09
1250	677	2.27
1300	704	2.46
1350	732	2.65
1400	760	2.85
1450	788	3.06
1500	815	3.27
1550	843	3.49
1600	871	3.72
1650	899	3.95
1700	927	4.18
1750	954	4.43
1800	982	4.67
1850	1010	4.93
1900	1038	5.18
1950	1066	5.45
2000	1093	5.72

TEMP F	TEMP C	MILLIVOLTS
2050	1121	5.98
2100	1149	6.26
2150	1177	6.55
2200	1204	6.83
2250	1232	7.12
2300	1260	7.42
2350	1288	7.72
2400	1316	8.02
2450	1343	8.32
2500	1371	8.63
2550	1399	8.94
2600	1427	9.26
2650	1454	9.57
2700	1482	9.89
2750	1510	10.21
2800	1538	10.54
2850	1566	10.86
2900	1593	11.18
2950	1621	11.51
3000	1649	11.83

Figure 9: thermocouple temp/millivolt chart

8.5 Useful Formulas

Fahrenheit to Celsius

$$C = (5/9) \times (F - 32)$$

Example: F = 100

$$C = .56 \times 68 = 38$$

Celsius to Fahrenheit

$$F = (C \times 9/5) + 32$$

Example: C = 100

$$F = 100 \times 1.8 + 32 = 212$$

Celsius to Kelvin

$$K = C + 273$$

Example: C = 100

$$100 + 273 = 373$$



9 CUSTOMER SUPPORT

Americas	Asia	Europe
<u>support.na@upc-marathon.com</u>	<u>service@mmichina.cn</u>	<u>support.eu@upc-marathon.com</u>
USA: +1 414 462 8200	Shanghai: +86 21 3463 0376	France: +33 3 81 48 37 37
Canada: +1 514 335-7191	Beijing: +86 10 8217 6427	Germany: +49 7161 94888-0
		Poland: +48 32 296 66 00

Reach us at www.upc-marathon.com

UPC-Marathon brings together leading brands to the heat-treating industry including Atmosphere Engineering, Furnace Control, Marathon Monitors, Process-Electronic, and Waukee Engineering. We provide prime control solutions through our worldwide sales and services network with easy-to-access local support.

